

SGS SWS7224

OWNER'S MANUAL

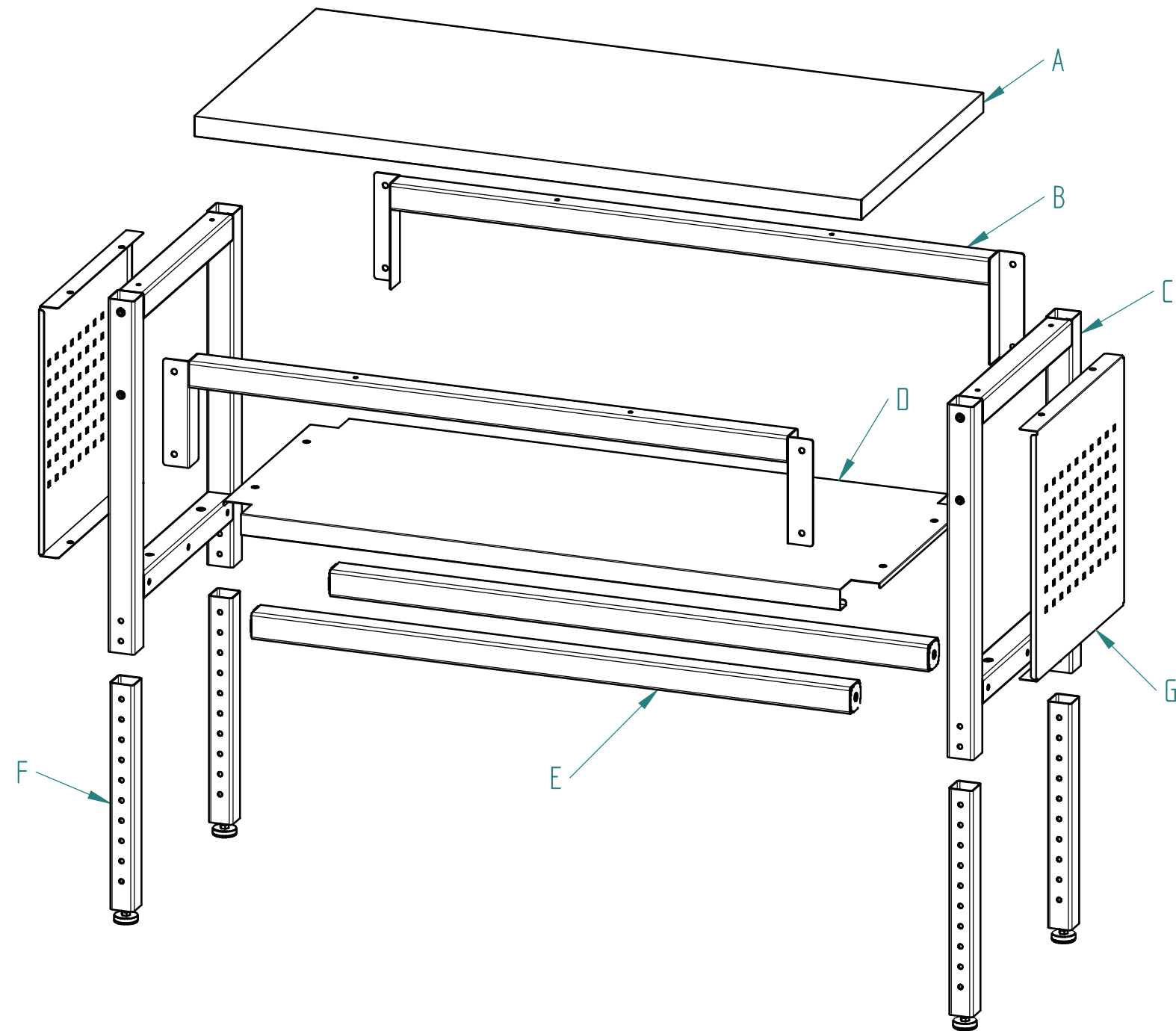

PARTS LIST

ITEM	DESCRIPTION	QTY.
A	Worktop	1
B	Underboarding	2
C	Leg	2
D	Shelf	1
E	Support Panel	2
F	Extend Leg	4
G	Side Panel	2

HARDWARE CONTENTS

NO.	DESCRIPTION	QTY.
a	Screws ST6.3x25 mm	8+3/10+1
b	Bolts M8x16 mm	16+1
c	Bolts M8x65 mm	12+1
d	Washers 8 mm	12+1
e	Nuts M8	8

⚠ Finally tighten the hardware

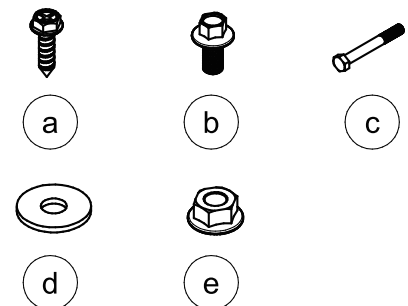

FOR YOUR SAFETY
PLEASE READ THESE INSTRUCTIONS CAREFULLY
AND RETAIN THEM FOR FUTURE USE.



FASTENERS

Step 1

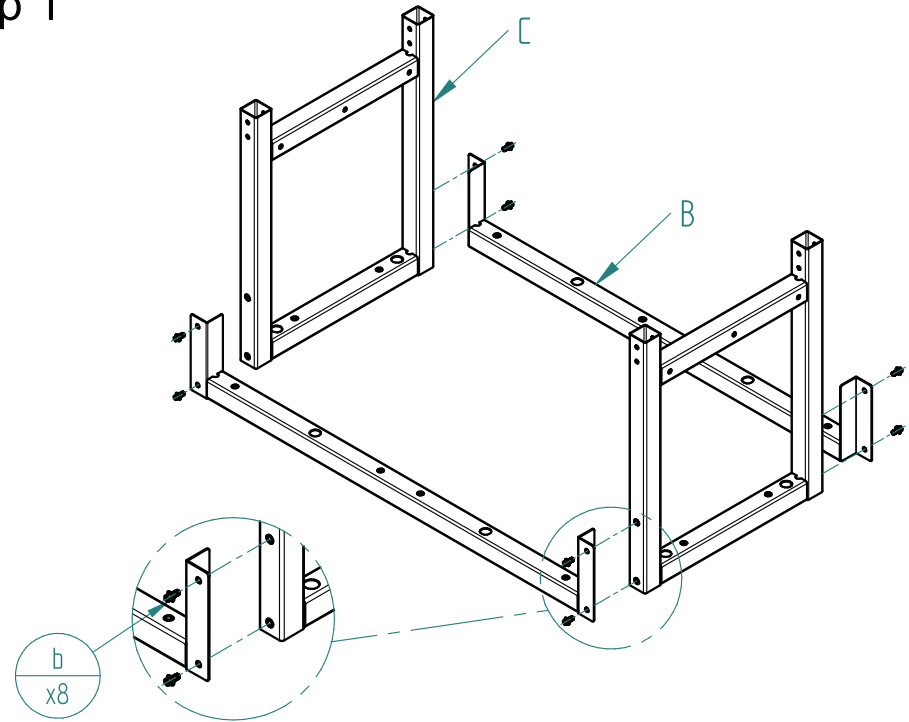

Step 2

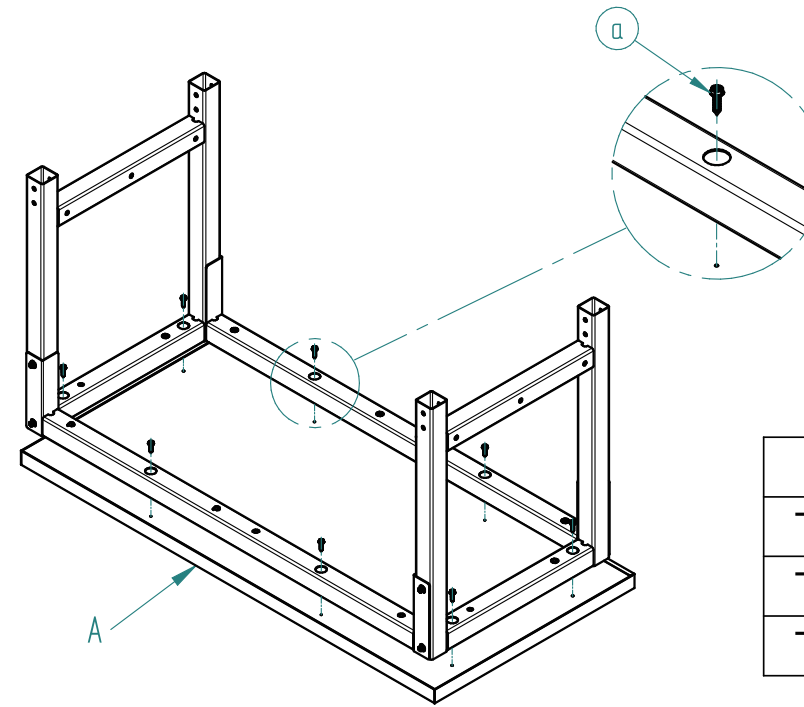

PRODUCT	QTY.
TSP5024/TSP5024-S	8
TSP6024/TSP6024-S	8
TSP7224/TSP7224-S	10

Step 3

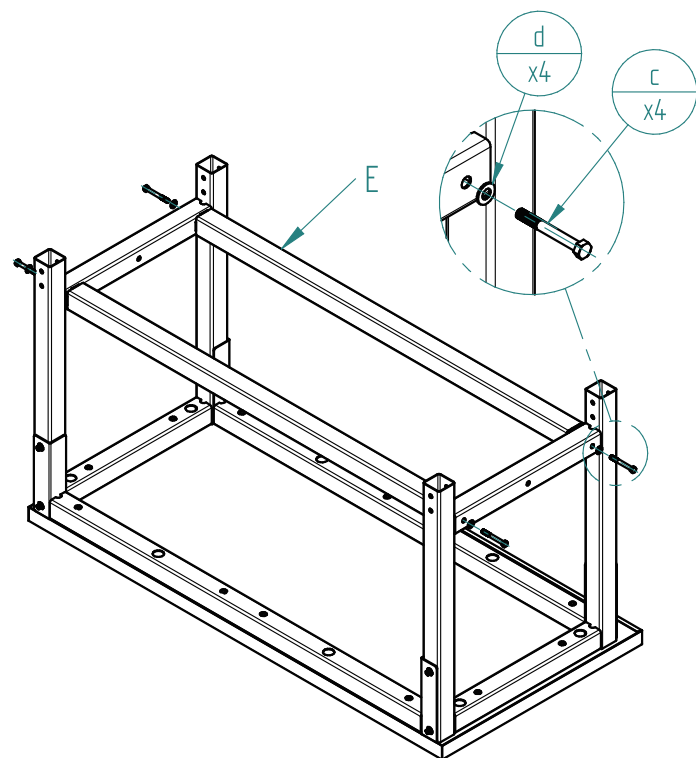

Step 4

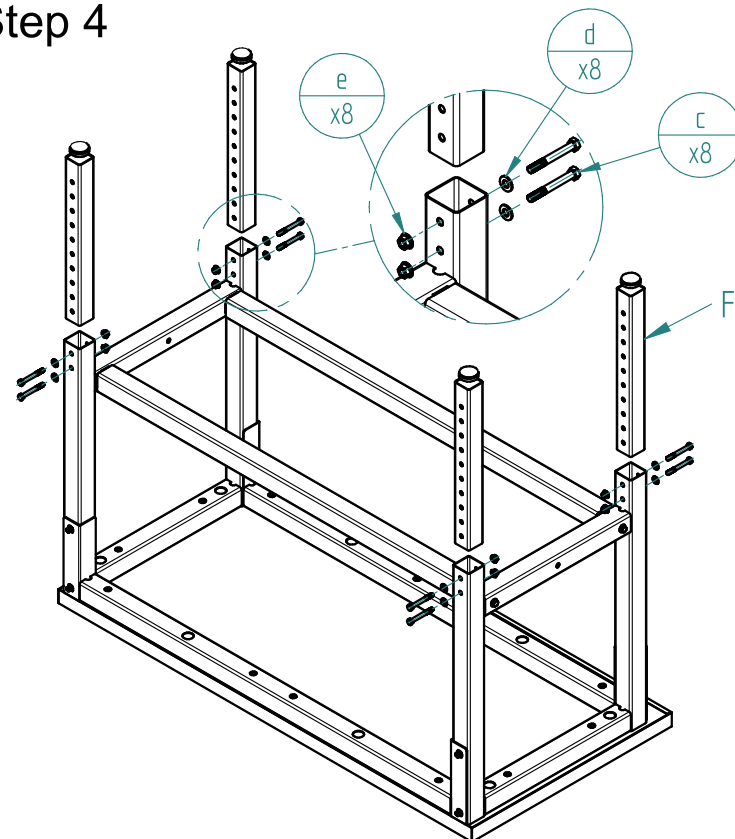

Step 5

